

## BREMI Coils Replacement with BOSCH

The replacement took place when one of my coils failed, causing the engine light to turn on. After reading all the fuss made about the failure rate of Bremi coils, I suspected that I was a victim as well.

A quick visit to the dealer got me 6 brand new Bosch coils at £14.00 each. They already knew that Bremi coils had issues.

Installation difficulty: 2 out of 5 (because you have to run to a shop to erase the fault code)

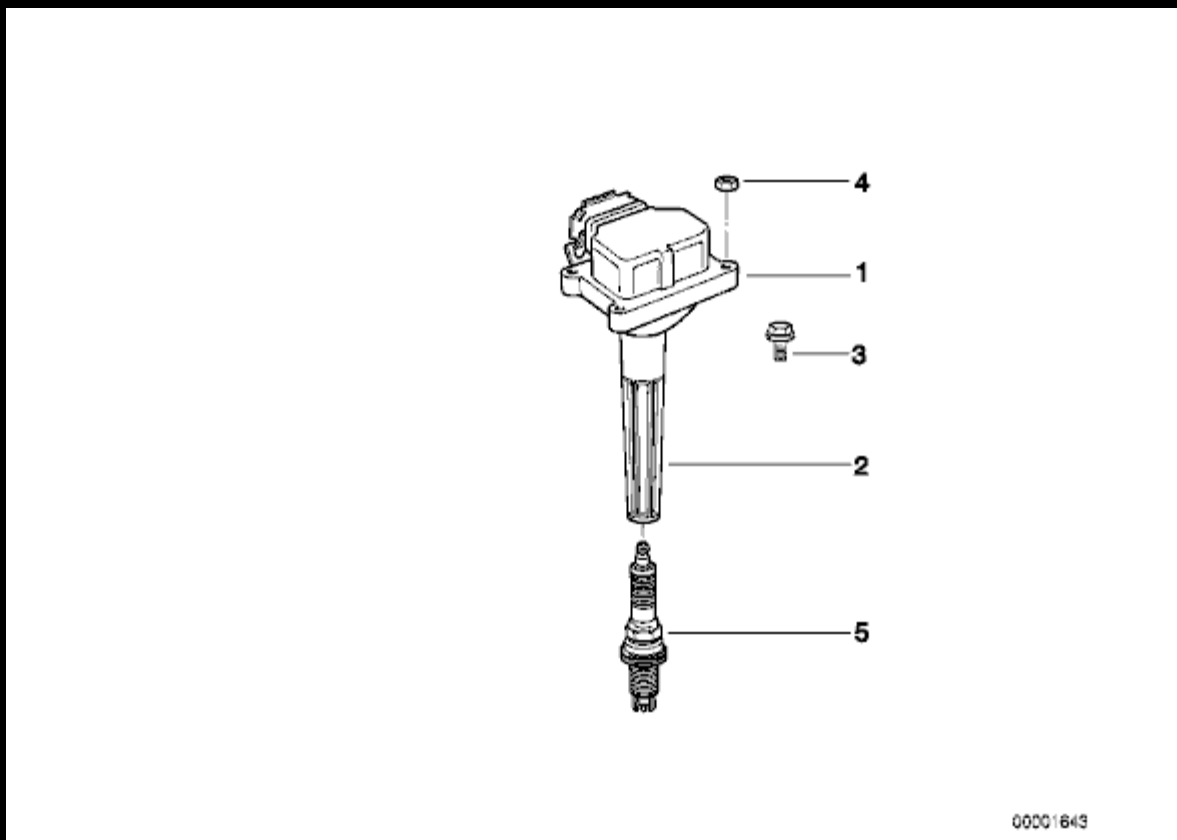

No.	Description	Supplement	Qty	From	Up To	Part Number	Price	Notes
01	IGNITION COIL	BOSCH	6	09/2002	12/31/2002	12131703228		ENDED
01	IGNITION COIL	BREMI	6	09/2002		12131748018	\$83.70	
01	IGNITION COIL	BOSCH	6	10/2002		12131703228		ENDED
01	IGNITION COIL	BREMI	6	10/2002		12131748018	\$83.70	
02	SPARK PLUG SOCKET		6	09/2002		12139067831	\$14.17	
02	SPARK PLUG SOCKET		6	10/2002		12139067831	\$14.17	
03	HEX BOLT WITH WASHER	M6X25-Z1-ZNS	12	09/2002		07119900249	\$0.50	
03	HEX BOLT WITH WASHER	M6X25-U1-8.8	12	09/2002		07119905400	\$4.46	
03	HEX BOLT WITH WASHER	M6X25-Z1-ZNS	12	10/2002		07119900249	\$0.50	
03	HEX BOLT WITH WASHER	M6X25-U1-8.8	12	10/2002		07119905400	\$4.46	
05	SPARK PLUG, HIGH POWER	BOSCH FGR7DQP	6			12120141871	\$16.63	

05	SPARK PLUG, HIGH POWER	NGK BKR6EQU 6		12129071003	\$16.63
05	SPARK PLUG, HIGH POWER	BOSCH FGR7DQP	6	09/2002 12120141871	\$16.63
05	SPARK PLUG, HIGH POWER	NGK BKR6EQU 6		09/2002 12129071003	\$16.63

1. Remove the cabin air filter assembly! How to do this is written on the [blower fan DIY](#).
2. Remove the engine cover by popping the 2 small covers and removing the 2 nuts below. 12mm If I remember correctly.
3. Remove the 3-pin plug from each coil
4. Twist 90 degrees counterclockwise each coil and pull it out. Now it's a good time to change the spark plugs if you need to.
5. Insert the new coils in the exact way; insert, twist.
6. Plug the wires back and start the engine. Verify it's running properly before placing the covers back.
7. Re-install the engine cover, cabin filter and you are good to go!